

LIQUI-BOX STARASEPT

RELIABLE AND ROBUST ASEPTIC
BULK FILLING SOLUTION.

The StarAsept filling system locks in quality and assures the safety of your products by eliminating chemical sterilants, minimizing oxygen penetration, and streamlining the filling zone.

OPTIMIZED STERILIZATION

The steam sterilization ensures high sterile efficiency, reduces utility cost and ensures optimal fitment sterilization for your application. Our patented StarAsept sterilization chamber ensures a closed sterile environment during the entire filling processes.

DESIGNED FOR SAFETY

The StarAsept filling system is CE Certified as well as meeting local safety regulations.

RELIABILITY

This extremely reliable fitment and filler system for low and high acid aseptic bulk fill applications has years of proven use with outstanding success and reliability that will maximize your production up-time. Our efficient sterilization system ensures that your products are safely and aseptically packaged every filling cycle. In addition our load cell filling management system ensures a highly accurate fill for your products.



LIQUI-BOX

DESIGN. CONNECT. DELIVER.

STANDARD FEATURES

SIMPLE, USER-FRIENDLY INTERFACE

Fail-safe controls and user friendly operation are key points that distinguish the StarAsept in the aseptic bulk packaging arena.

LOW TOTAL COST OF OWNERSHIP

The efficient sterilization combined with the reliability of the StarAsept deliver savings for your bulk filling process.

FILLER + FITMENT

The StarAsept filler uses proprietary fitment technology to preserve your product through the entire packaging, filling and distribution process. This extremely reliable fitment and filler system for low and high acid aseptic bulk fill applications has demonstrated proven benefits over years of use.

RATE OF FILL

The following numbers are average filling rates recorded in various client facilities. Actual rate is dependent on operator dexterity, product supply rate and bag size.

The StarAsept fills up to 100 gallons per minute (378.5 liters per minute) and is capable of filling a range of bags from 6 gallons (22.7 liters) to 370 gallons (1,400 liters)

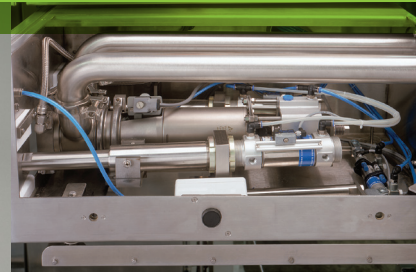

DELIVERING VALUE FOR YOUR PRODUCTS

The StarAsept filler and fitment deliver reliable and efficient performance for bulk packaging for your high and low-acid aseptic products. With established acceptance as a leading tote sized bag filler, the StarAsept is suitable for vegetables, tomato products, condiments, cheese sauces, gravies, syrups, juices and many other liquid foods for the industrial and food service markets.

The reliable low cost operation of the StarAsept filling system ensure your products are safely packaged day in and day out.

87" D x 94" W x 115" H
(220cm D x 237cm W x 292cm H)

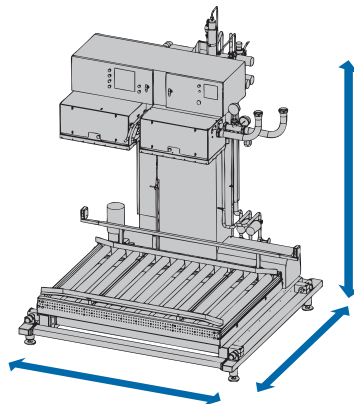

Global headquarters
1-800-260-4376

Worldwide locations
liquibox.com

 LIQUI-BOX